

Crew Rest Couch - CRC

technical aspects

NOVEMBER 2019



(expleo)

Comfort Design

convert your
ECO seats into a
Crew Rest Couch

install
3 units

fold out
supports

remove,
and stow in
overhead bin



no tools
needed

Key Characteristics

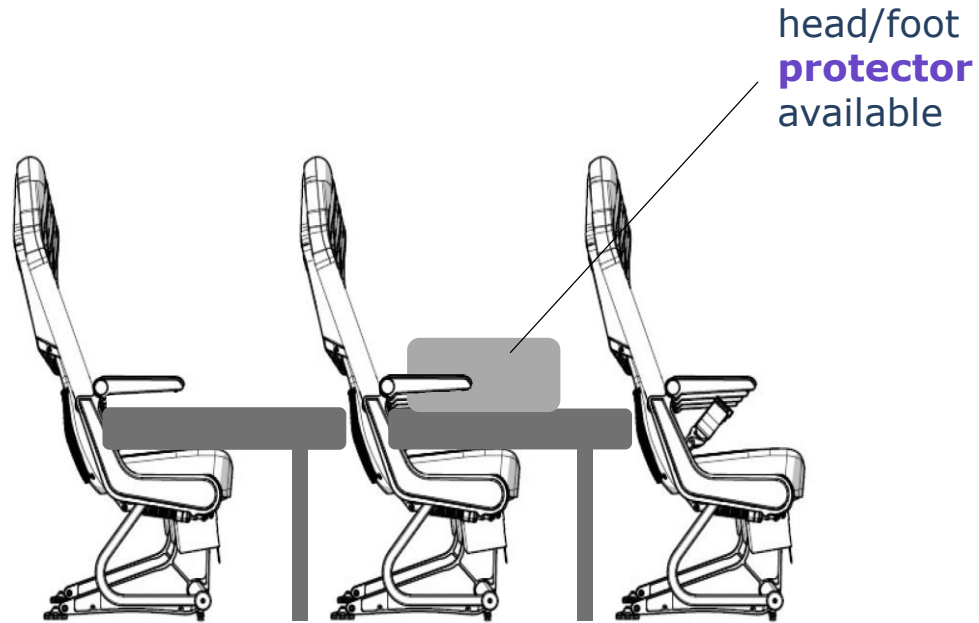

no modification
of seats required

device fits to
standard ACRO
series 3 seat



- keep one-class-layout
- category: loose equipment (carry on)
- for extension of FDP
- FST requirements according **25.853 (c) Appendix F**, Part II
- to be stored during Taxi, Take-off and Landing
- no LOPA change required: **light-weight, flexible, cost-effective**

Dimensions

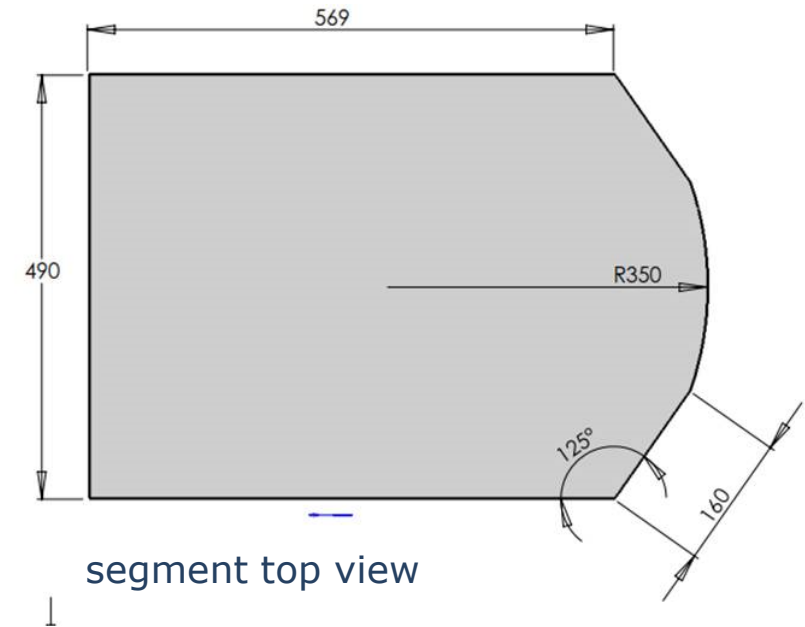
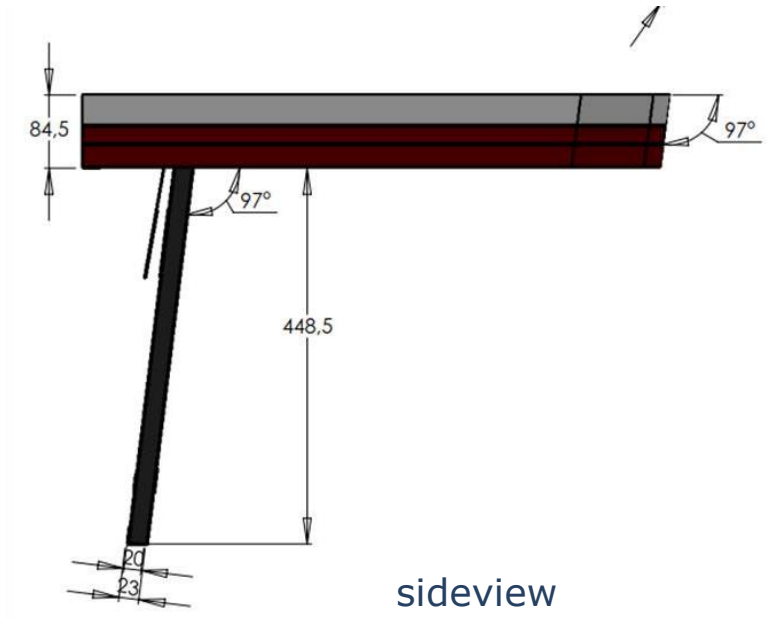



Joachim Lau

Sales Director Aerospace • Hamburg • Germany

T. +49 (0) 40 743 65407 • M. +49 (0) 176 10 03 62 67

Joachim.lau@expleogroup.com

[expleogroup.com](https://www.expleogroup.com)